

## B SERIES (Indoor, Keyed)

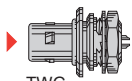

### Metal housing models (page 14)

#### Fixed plugs



TWG

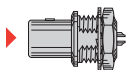

TAG

#### Elbow (90°) plug

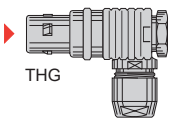

THG

#### Straight plugs



TGG



TGG



TFG

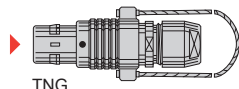

TNG



TEG

#### Fixed sockets

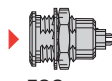

ZGG

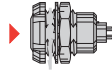

ZCG

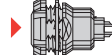

ZEG

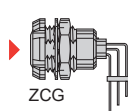

ZCG

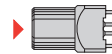

ZZG

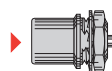

ZHG

#### Free sockets

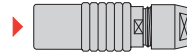

DHG



DHG

#### Fixed sockets

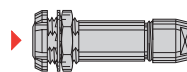

DFG

### Elbow socket models (page 20)

#### Elbow sockets

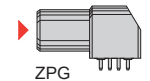

ZPG

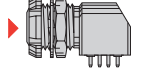

ZXG

### Watertight or vacuumtight models (page 18)

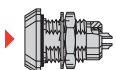

MGG

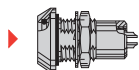

MHG

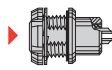

MEG

## Part Section Showing Internal Components

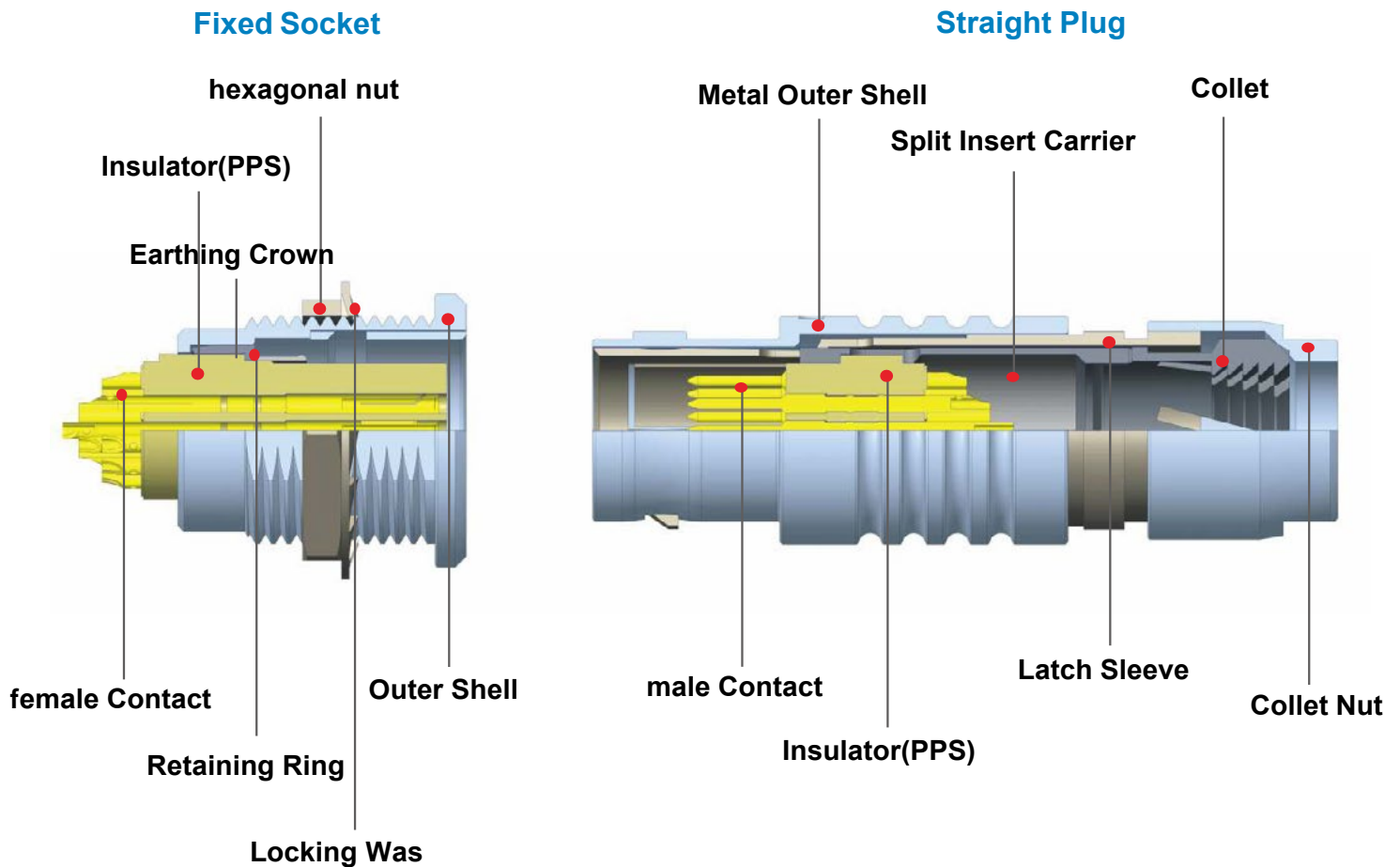

### B Series Connectors Provide The Following Main Features:

- security of the Push-Pull self-latching system
- multipole types 2 to 26 contacts
- solder, crimp or print contacts (straight or elbow)
- high packing density for space savings
- multiple key options to avoid cross mating of similar connectors
- keying system («G» key standard) for connector alignment
- 360° screening for full EMC shielding.

### B Series Connectors Technical Characteristics :

- Endurance: > 5000 cycles
- Humidity: up to 95% at 60° C
- Temperature range: - 45° C, + 125° C
- Resistance to vibrations: 10-2000 Hz, 15g
- Shock resistance: 100 g, 6 ms
- Salt spray corrosion test: > 48h
- Protection index (mated): IP 50

## B Series Part Numbering System

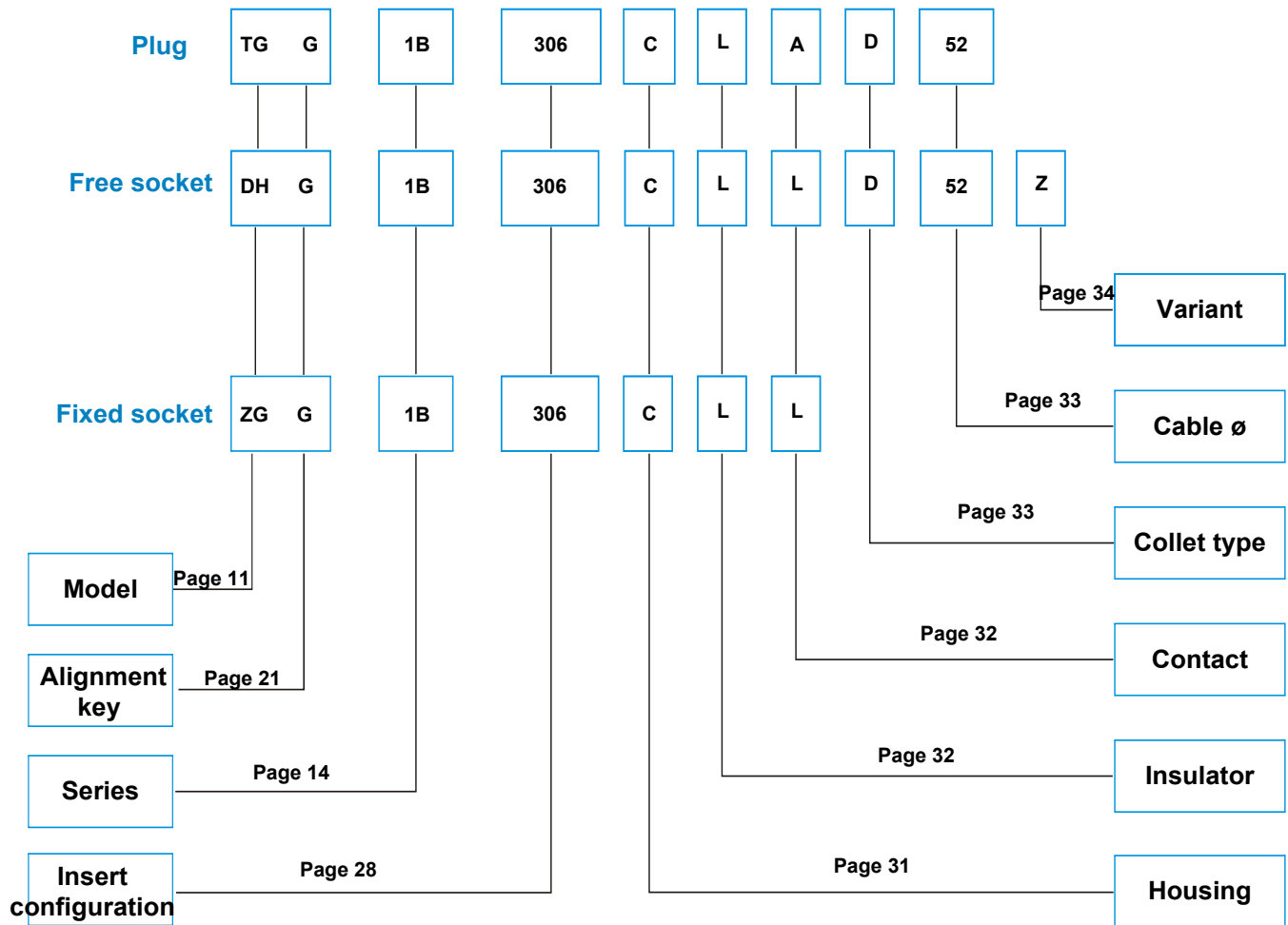

### Part Number Example

#### Straight Plug with Cable Collet:

**TGG.1B.306.CLAD52** = straight plug with key (G) and cable collet, 1B series, multipole type with 6 contacts, outer shell in chrome-plated brass, PPS insulator, male solder contacts, D type collet for 5.0 mm diameter cable.

#### Free socket:

**DHG.1B.306.CLLD52Z** = free socket with key (G) and cable collet, 1B series, multipole type with 6 contacts, outer shell in chrome-plated brass, PPS insulator, female solder contacts, D type collet for 5.0 mm diameter cable and nut for fitting a bend relief.

#### Fixed Socket:

**ZGG.1B.306.CLL** = fixed socket, nut fixing, with key (G), 1B series, multipole type with 6 contacts, outer shell in chrome-plated brass, PPS insulator, female solder contacts.

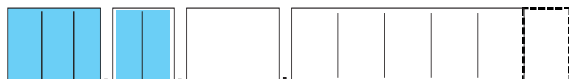

## Metal Housing Models

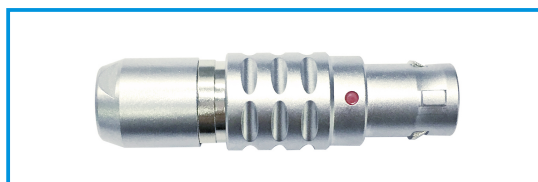

### TGG Straight plug, key (G) or keys (A...M and R), cable collet

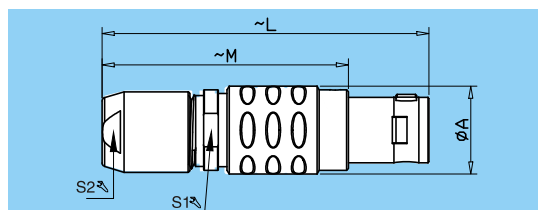

Reference		Dimensions (mm)				
Series	Model	A	L	M	S1	S2
00B	TGG	6.4	28.5	20.5	5.5	5.0
0B	TGG	9.5	36.0	26.0	8.0	7.0
1B	TGG	12.0	43.0	32.0	10.0	9.0
2B	TGG	15.0	50.0	38.0	13.0	12.0
3B	TGG	18.0	58.0	43.0	15.0	14.0

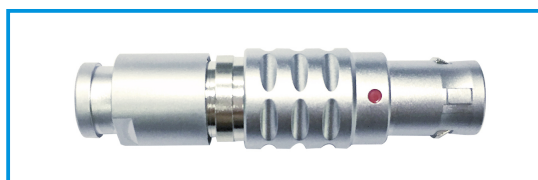

### TGG Straight plug, key (G) or keys (A M), cable collet and nut for fitting a bend relief

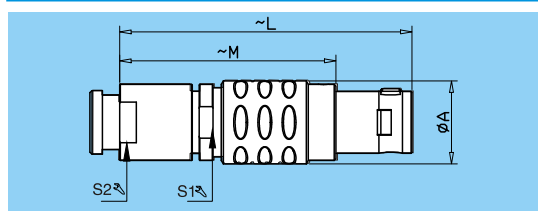

Reference		Dimensions (mm)				
Series	Model	A	L	M	S1	S2
00B	TGG	6.4	36.5	28.5	5.5	6.0
0B	TGG	9.5	35.5	25.0	8.0	7.0
1B	TGG	12.0	42.0	31.0	10.0	9.0
2B	TGG	15.0	49.0	37.0	13.0	13.0
3B	TGG	18.0	56.5	42.0	15.0	15.0

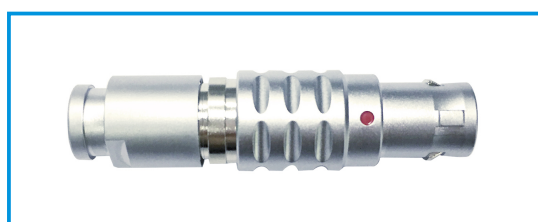

### TEG Straight plug, key (G) or keys (A...L), cable collet, front seal and nut for fitting a bend relief (IP 54 protection index when mated)

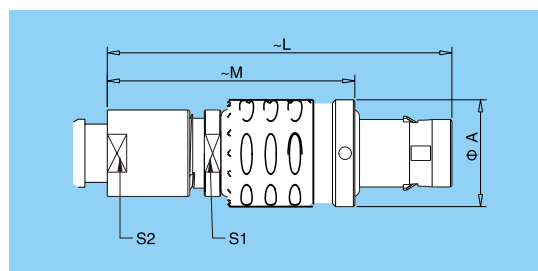

Reference		Dimensions (mm)				
Series	Model	A	L	M	S1	S2
0B	TEG	11.0	35.0	25.0	8	7
1B	TEG	13.5	42.0	33.0	10	9
2B	TEG	16.5	48.0	36.0	13	12
3B	TEG	19.0	56.0	41.5	15	15

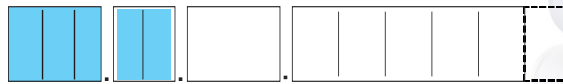

B series



**TFG** Straight plug, non-latching, key (G) or keys (A...M), cable collet and nut for fitting a bend relief

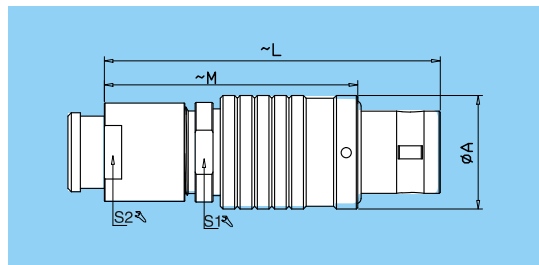

Reference		Dimensions (mm)				
Series	Model	A	L	M	S1	S2
0B	TFG	9.5	36	26	8.0	7.0
1B	TFG	12.0	43	32	10.0	9.0
2B	TFG	15.0	50	38	13.0	12.0
3B	TFG	18.0	58	43	15	14



**TNG** Straight plug, key (G) or keys (A...M and R), cable collet and lanyard release

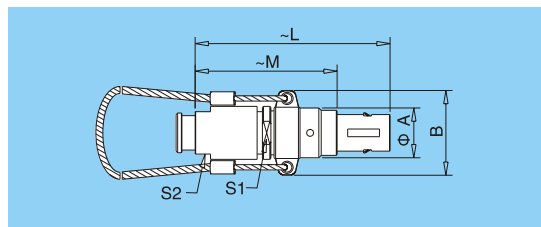

Reference		Dimensions (mm)						
Series	Model	A	B	L	M	N	S1	S2
0B	TNG	9.5	15.5	36.0	26.0	140	8	7
1B	TNG	12.0	18.0	43.0	32.0	140	10	9
2B	TNG	15.0	21.0	49.0	37.0	160	13	12
3B	TNG	18.0	25.0	58.0	43.0	190	15	14

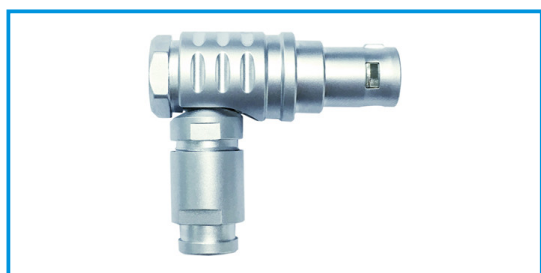

**THG** Elbow (90°) plug, key (G) or keys (A...M and R), cable collet

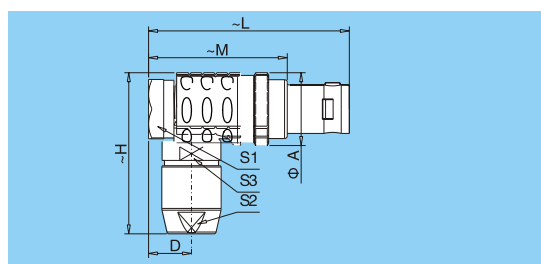

Reference		Dimensions (mm)							
Series	Model	A	D	H	L	M	S1	S2	S3
0B	THG	11.0	6.5	26.0	31.6	21.6	10	7	8.0
1B	THG	13.5	8.0	30.5	36.0	25.0	11	9	10.0
2B	THG	16.5	9.0	34.0	41.5	29.5	14	12	13.0
3B	THG	19.0	10.0	37.0	50.0	35.0	17	14	15.0

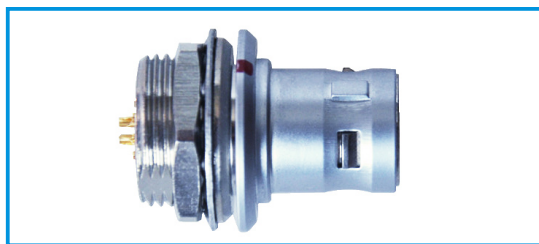
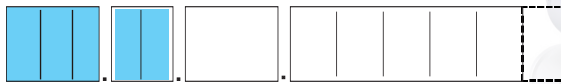

**TWG Fixed plug, nut fixing, key (G) or keys (A...L)**

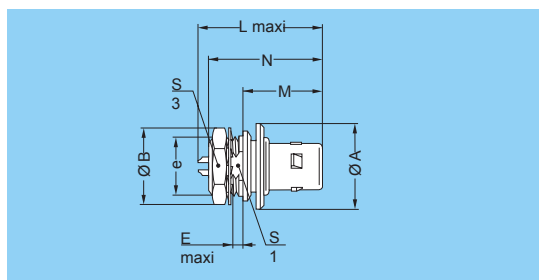

Reference		Dimensions (mm)							
Series	Model	A	B	e	E	L	M	S1	S3
1B	<b>TWG</b>	12	12.4	M9x0.6	2.4	2.5	18.3	8.2	11
2B	<b>TWG</b>	16	15.8	M12x1.0	6.0	3.5	20.3	10.5	14

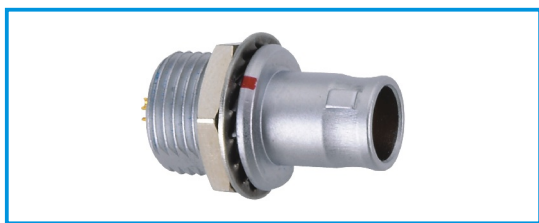

**TAG Fixed plug, non-latching, nut fixing, key (G) or keys (A...M and R)**

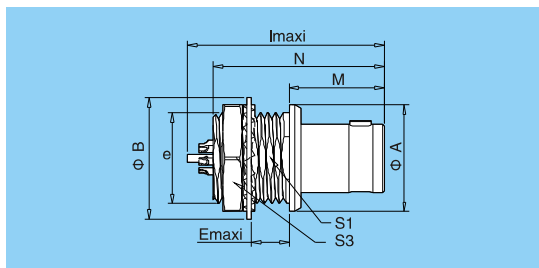

Reference		Dimensions (mm)							
Series	Model	A	B	e	E	L	M	N1)	S1
0B	<b>TAG</b>	10	12.4	M9x0.6	4.2	20.8	11.2	18.9	8.2
1B	<b>TAG</b>	14	15.8	M12x1.0	5.4	25.2	12.5	21.6	10.5
2B	<b>TAG</b>	18	19.2	M15x1.0	6.0	28.7	13.8	23.9	13.5
3B	<b>TAG</b>	22	25.0	M18x1.0	5.8	32.1	17.0	30.2	16.5

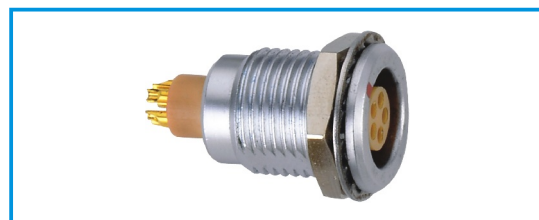

**ZGG Fixed socket, nut fixing, key (G) or keys (A...M and R)(front panel mounting)**

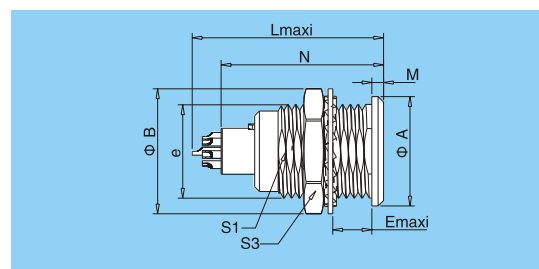

Reference		Dimensions (mm)								
Series	Model	A	B	e	E	L	M	N1)	S1	S3
00B	<b>ZGG</b>	8	10.2	M7x0.5	6.0	15.5	1.0	13.7	6.3	9
0B	<b>ZGG</b>	10	12.4	M9x0.6	7.0	20.7	1.2	19.1	8.2	11
1B	<b>ZGG</b>	14	15.8	M12x1.0	7.5	23.0	1.5	21.1	10.5	14
2B	<b>ZGG</b>	18	19.2	M15x1.0	8.5	26.7	1.8	24.6	13.5	17
3B	<b>ZGG</b>	22	25.0	M18x1.0	11.5	30.7	2.0	28.1	16.5	22

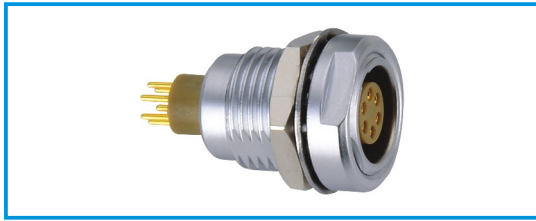
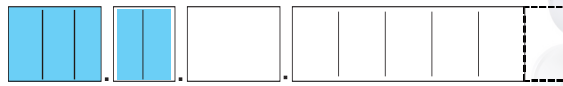

**ZCG Fixed socket with two nuts, key (G) or keys (A...M and R) (back panel mounting)**

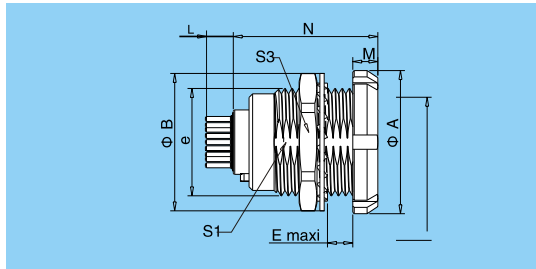

Reference		Dimensions (mm)								
Series	Model	A	B	e	E	L	M	N	S1	S3
0B	ZCG	12	12.4	M9x0.6	5.5	20.7	2.5	19.1	8.2	11
1B	ZCG	16	15.8	M12x1.0	6.0	23.0	3.5	21.1	10.5	14
2B	ZCG	20	19.2	M15x1.0	6.5	26.7	3.5	24.6	13.5	17
3B	ZCG	24	25.0	M18x1.0	9.0	30.7	4.5	28.1	16.5	22

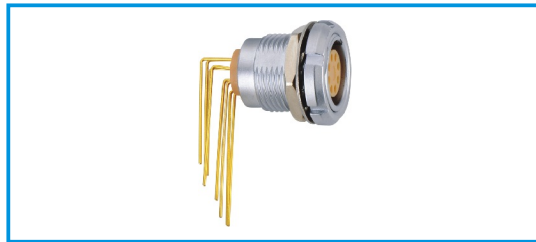

**ZCG Fixed socket with two nuts, key (G) or keys (A...F) with elbow (90°) contact for printed circuit (back panel mounting)**

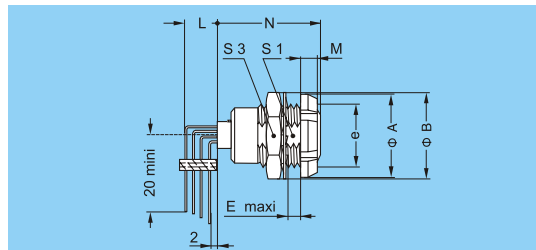

Reference		Dimensions (mm)								
Series	Model	A	B	e	E	M	N <sub>max</sub>	S1	S3	
0B	ZCG	12	12.4	M9x0.6	2.4	2.5	18.3	8.2	11	
1B	ZCG	16	15.8	M12x1.0	6.0	3.5	20.3	10.5	14	
2B	ZCG	20	19.2	M15x1.0	6.5	3.5	22.3	13.5	17	
3B	ZCG	24	25.0	M18x1.0	9.0	4.5	25.8	16.5	22	

**Note:** Length «L» depends on the number of contacts, see PCB drilling pattern on page 37.

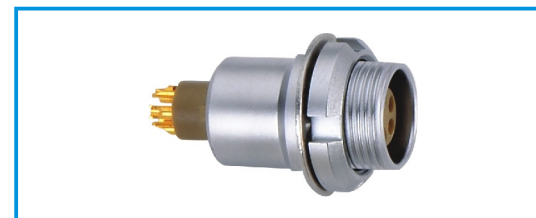

**ZEG Fixed socket, nut fixing, key (G) or keys (A...M and R) (back panel mounting)**

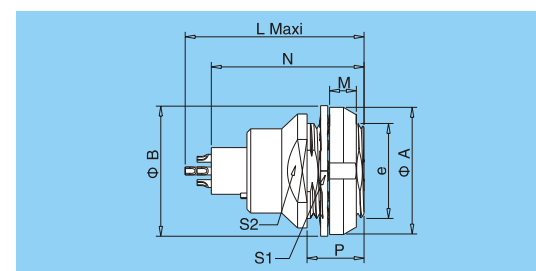

Reference		Dimensions (mm)								
Series	Model	A	B	e	E	L	M	N1)	P	S3
0B	ZEG	12	12.5	M9x0.6	2.4	20.7	2.5	19.1	6.3	8.2
1B	ZEG	16	16.0	M12x1.0	6.5	23.0	3.5	21.1	11.0	10.5
2B	ZEG	20	20.0	M15x1.0	3.0	26.7	3.5	24.6	9.0	13.5
3B	ZEG	24	25.0	M18x1.0	5.0	30.7	4.5	28.1	12.0	16.5

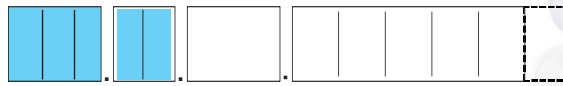

**MGG Fixed socket, nut fixing, key (G) or keys (A...M and R), watertight or vacuumtight**

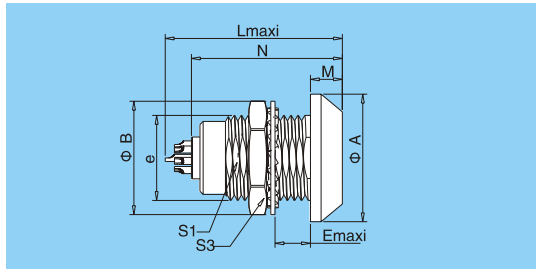

Reference		Dimensions (mm)							
Series	Model	A	B	e	E <sub>max</sub>	L	M	S1	S3
0B	<b>MGG</b>	13	12.4	M9x0.6	7.0	20.2	3.0	8.2	11
1B	<b>MGG</b>	18	15.8	M12x1.0	7.0	26.6	4.5	10.5	14



**MHG Fixed socket, nut fixing, key (G) or keys (A...M), watertight or vacuumtight (watertight when mated)**

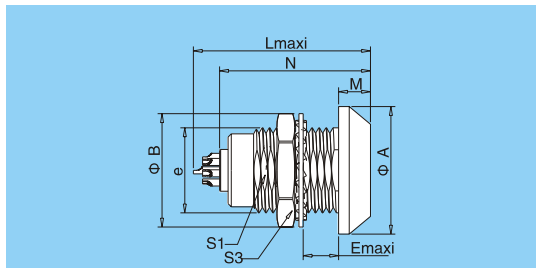

Reference		Dimensions (mm)							
Series	Model	A	B	e	E	L	M	S1	S3
0B	<b>MHG</b>	13	12.4	M9x0.6	7.0	23.2	4.8	8.2	11
1B	<b>MHG</b>	18	15.8	M12x1.0	7.0	30.3	5.2	10.5	14
2B	<b>MHG</b>	22	19.2	M15x1.0	8.0	35.6	6.0	13.5	17



**MEG Fixed socket, nut fixing, key (G) or keys (A...M), watertight or vacuumtight (back panel mounting)**

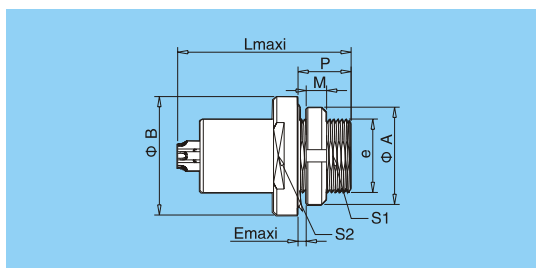

Reference		Dimensions (mm)								
Series	Model	A	B	e	E	L	M	P	S1	S3
0B	<b>MEG</b>	12	13	M9x0.6	5.5	20.2	2.5	9.0	8.2	-
1B	<b>MEG</b>	16	18	M12x1.0	5.5	26.6	3.5	11.0	10.5	-
2B	<b>MEG</b>	20	20	M15x1.0	5.5	31.6	3.5	9.6	13.5	15



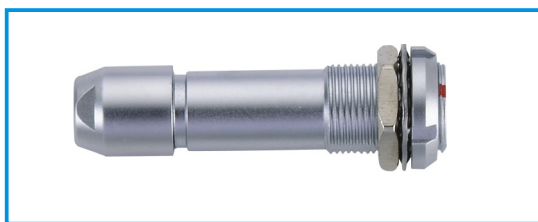

**DFG Fixed socket, with two nuts, key (G) or keys (A...M and R), cable collet (back panel mounting)**

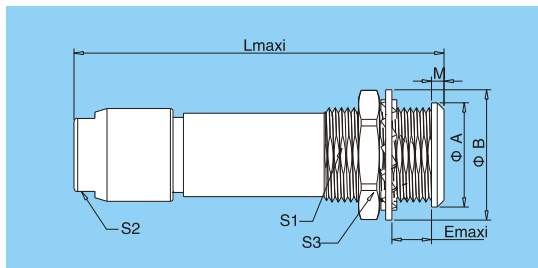

Reference		Dimensions (mm)								
Series	Model	A	B	e	E	L	M	S1	S2	S3
0B	DFG	10	12.4	M9x0.6	7.0	35.5	1.2	8.2	7	11
1B	DFG	14	15.8	M12x1.0	7.5	40.5	1.5	10.5	9	14
2B	DFG	18	19.2	M15x1.0	8.5	47	1.8	13.5	12	17
3B	DFG	22	25.0	M18x1.0	11.5	56	2.0	16.5	14	22



**DHG Free socket, key (G) or keys (A...M and R), cable collet**

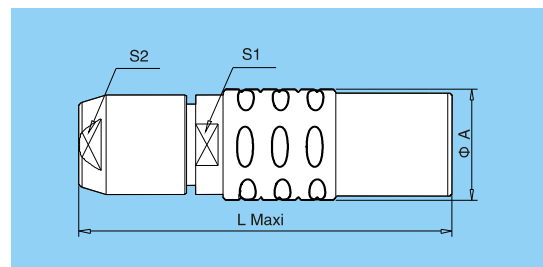

Reference		Dimensions (mm)			
Series	Model	A	L	S1	S2
0B	DHG	9.5	35.5	8.0	7.0
1B	DHG	12.5	40.5	10.0	9.0
2B	DHG	16.5	47.0	13.0	12.0
3B	DHG	19.0	56.0	15.0	15.0

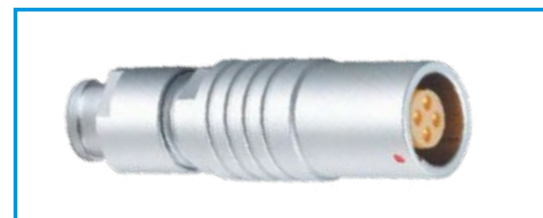

**DHG Free socket, key (K) or keys (A...M), cable collet and nut for fitting a bend relief**

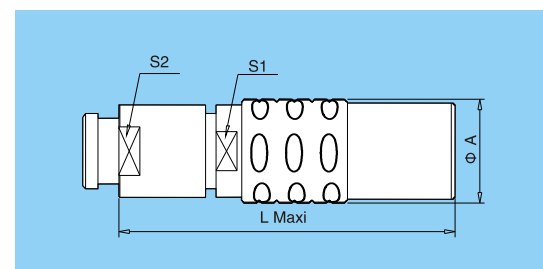

Reference		Dimensions (mm)			
Series	Model	A	L	S1	S2
0B	DHG	9.5	35.5	8.0	7
1B	DHG	12.5	40.5	10.0	9
2B	DHG	16.5	47.0	13.0	12
3B	DHG	19.0	56.0	15.0	14

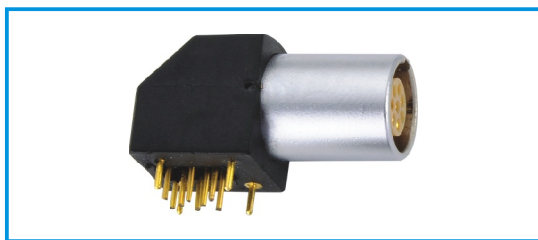
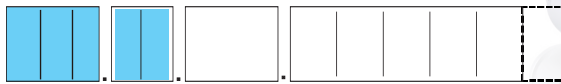

## ZPG Elbow (90°) socket for printed circuit, key (G) or keys (A...F) (solder or screw fixing)

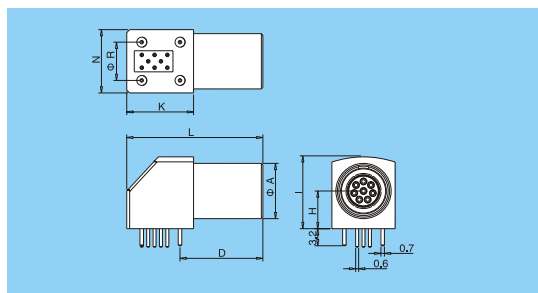

Part number	Dimensions (mm)							
	A	D	H	I	K	L	N	R
ZPG.0B.302.HLN	9.0	14.6	6.7	12.7	13.3	25.0	11.7	7.62
ZPG.0B.303.HLN								
ZPG.0B.304.HLN								
ZPG.0B.305.HLN								
ZPG.0B.306.HLN								
ZPG.0B.307.HLN	11.0	16.6	7.5	14.0	13.3	27.0	12.6	7.62
ZPG.1B.302.HLN								
ZPG.1B.303.HLN								
ZPG.1B.304.HLN								
ZPG.1B.305.HLN								
ZPG.1B.306.HLN								
ZPG.1B.307.HLN								
ZPG.1B.308.HLN								

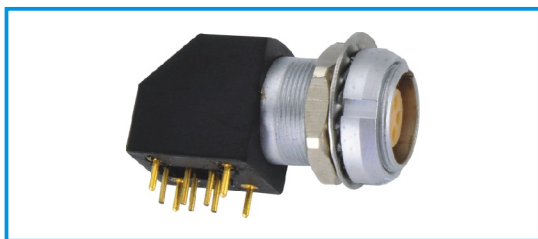

## ZXG Elbow (90°) socket for printed circuit with two nuts, key (G) or keys (A...F) (solder or screw fixing)(back panel mounting)

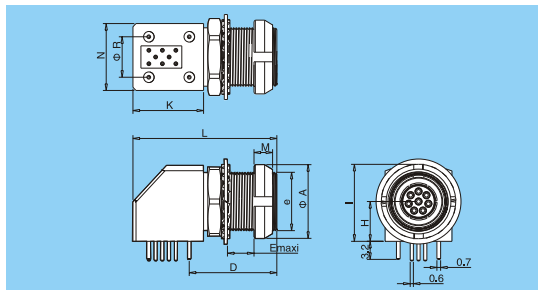

Part number	Dimensions (mm)												
	A	B	D	e	E	H	I	K	L	M	N	R	S3
ZXG.0B.302.HLN	12	12.4	14.6	M9x0.6	6.0	6.7	12.7	13.3	25.0	2.5	11.7	7.62	11
ZXG.0B.303.HLN													
ZXG.0B.304.HLN													
ZXG.0B.305.HLN													
ZXG.0B.306.HLN													
ZXG.0B.307.HLN	14	15.0	16.6	M11x0.5	7.5	7.5	14.0	13.3	27.0	3.5	12.6	7.62	13
ZXG.1B.302.HLN													
ZXG.1B.303.HLN													
ZXG.1B.304.HLN													
ZXG.1B.305.HLN													
ZXG.1B.306.HLN													
ZXG.1B.307.HLN													
ZXG.1B.308.HLN													

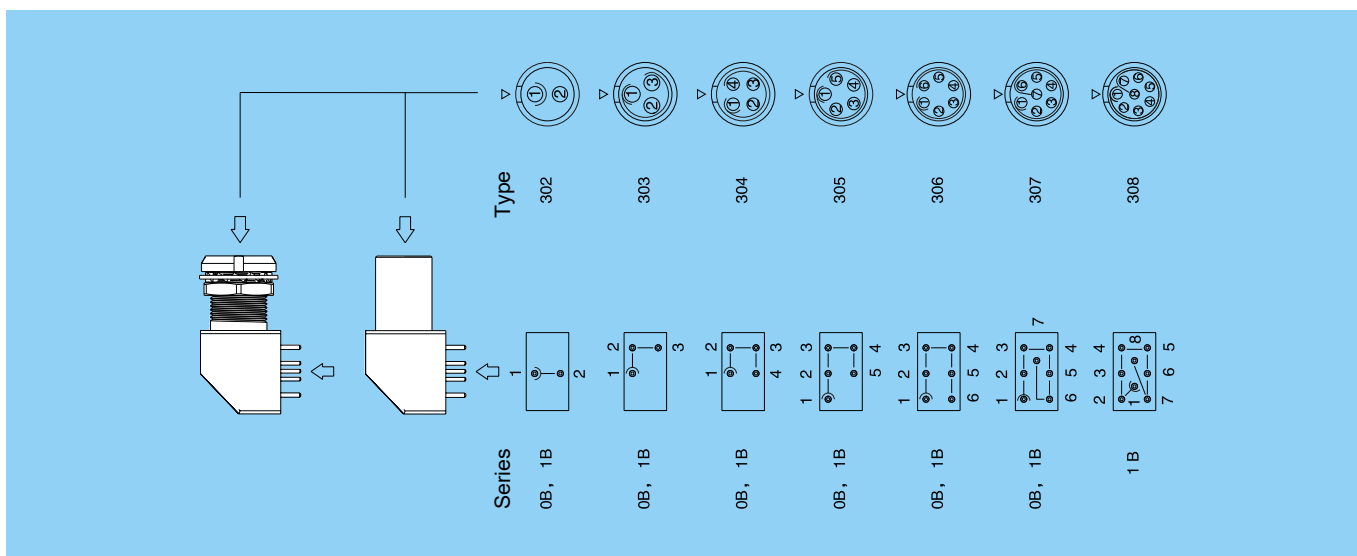

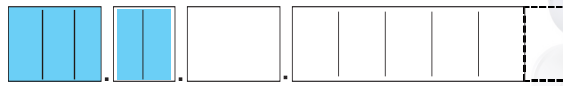

B series

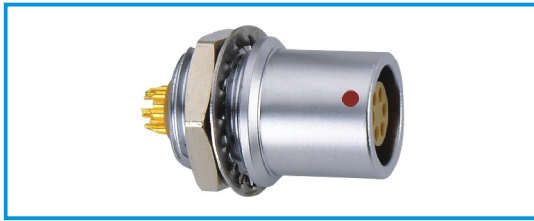

## ZHG Fixed socket, nut fixing, key (G) or keys (A...M and R), and protruding shell

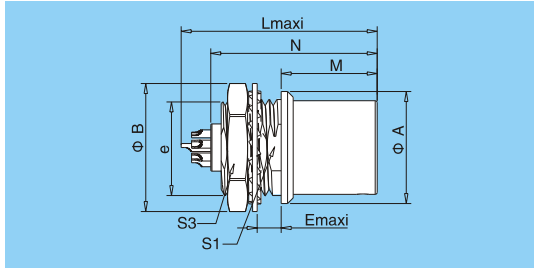

Reference		Dimensions (mm)								
Series	Model	A	B	e	E	L	M	N	S1	S3
0B	ZHG	10	12.4	M9x0.6	2	12.5	19.5	19.1	8.2	11
1B	ZHG	14	15.8	M12x1.0	4	12	21.7	21.1	10.5	14
2B	ZHG	18	19.2	M15x1.0	5.1	12.5	22.7	24.6	13.5	17
3B	ZHG	22	25	M18x1.0	7.1	13.5	30.7	30.3	16.5	22

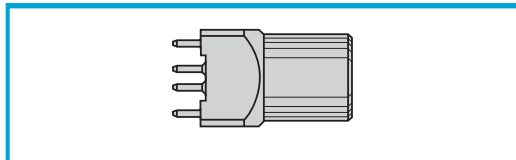

## ZZG Straight socket for printed circuit, key (G) or keys (A...F)

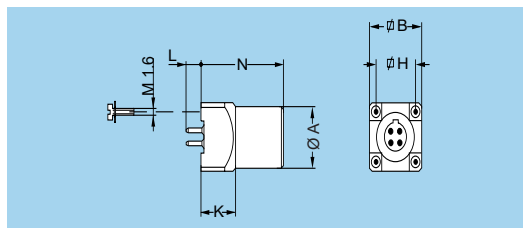

Reference		Dimensions ( mm )				
Model	Series	A	B	H	K	N
ZZG	0B	9	10	7.62	8	15.0
ZZG	1B	11	12	7.62	8	19.0
ZZG	2B	14	15	10.16	9	22.5

Note: Length «L» depends on the number of contacts

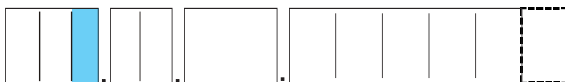

## Alignment Key (B series)

### Alignment Key and Polarized Keying System

B series connector model part numbers are composed of three letters. The LAST LETTER indicates the key position and the contact type (male or female)

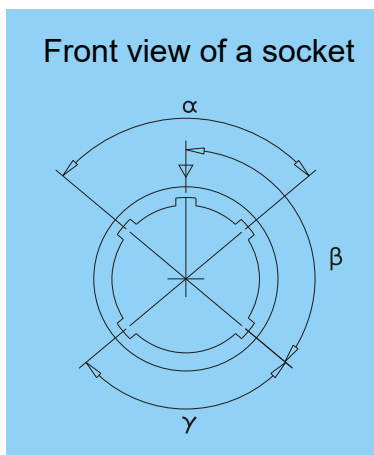

Ref.	Nb of keys	Angles	Series		Nb of keys	Angles	Series		Contact type	
			0B	1B			2B	3B	Plug	Socket
G	1		0°	0°	1		0°	0°	male	female
A	2	α	30°	30°	2	α	30°	30°	male	female
B	2		60°	60°	2		45°	45°	male	female
C	2		90°	90°	2		60°	60°	male	female
D	2		135°	135°	2		γ	95°	95°	male
E	2	β	145°	145°	2	β	120°	120°	male	female
F	2		155°	155°	2		145°	145°	male	female
J	2	γ	45°	45°	2	α	37.5°	37.5°	female	male

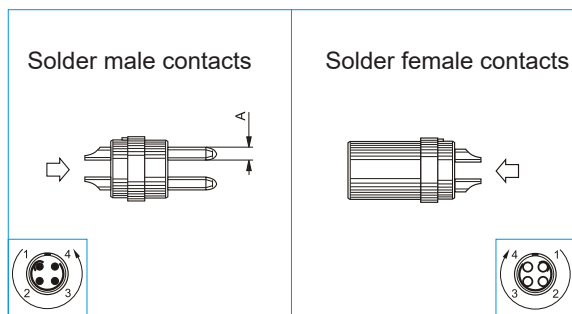

	Solder male contacts	Solder female contacts
<b>00</b>		
<b>0B</b>		
<b>1B</b>		

- First choice alternative
- Special order alternative

Reference	Multipole(contacts)	Φ A (mm)	Contact Type			Solder contact		Rated current (A)
			solder	Print (straight)	Print (elbow)	Test voltage (kV rms) Contact-contact	Test voltage (kV rms) Contact-shell	
302	2	0.5	●	●	●	1.00	0.95	5.0
303	3	0.5	●	●	●	0.80	0.95	3.0
304	4	0.5	●	●	●	0.80	0.65	2.0
302	2	0.9	●	●	●	1.30	1.05	10.0 <sub>1)</sub>
303	3	0.9	●	●	●	1.20	0.90	8.0 <sub>1)</sub>
304	4	0.7	●	●	●	0.85	0.70	7.0 <sub>1)</sub>
305	5	0.7	●	●	●	1.00	0.70	6.5 <sub>1)</sub>
306	6	0.5	●	●	●	0.85	0.65	2.5
307	7	0.5	●	●	●	0.80	0.70	2.5
309	9	0.5	●	●	○	0.60	0.50	2.0
302	2	1.3	●	●	●	1.50	1.35	15.0 <sub>2)</sub>
303	3	1.3	●	●	●	1.30	1.55	12.0
304	4	0.9	●	●	●	1.35	1.45	10.0 <sub>1)</sub>
305	5	0.9	●	●	●	1.25	1.15	9.0 <sub>1)</sub>
306	6	0.7	●	●	●	1.05	1.20	7.0 <sub>1)</sub>
307	7	0.7	●	●	●	0.95	1.05	7.0 <sub>1)</sub>
308	8	0.7	●	●	●	0.95	1.15	5.0
310	10	0.5	●	●	●	0.90	1.50	2.5
314	14	0.5	●	●	●	0.80	1.20	2.0
316	16	0.5	●	●	○	0.80	1.25	1.5

**Note :** 1) rated current = 6A for socket with elbow (90°) contact for printed circuit.  
 2) rated current = 12A for socket with elbow (90°) contact for printed circuit.  
 3) available only for connectors fitted with male contacts.

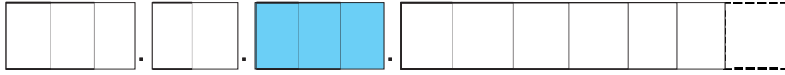

Solder male contacts

Solder female contacts

2B

- First choice alternative
- special order alternative

Reference	Multipole(contacts)	ΦA (mm)	Contact Type			Solder contact		Rated current (A)
			Solder	Print (straight)	Print (elbow)	Test voltage (kV rms) Contact-contact	Test voltage (kV rms) Contact-shell	
302	2	2.0	●	●	●	2.10	1.75	30.0 <sub>2)</sub>
303	3	1.6	●	●	●	2.40	1.85	17.0 <sub>2)</sub>
304	4	1.3	●	●	●	1.85	1.85	15.0 <sub>2)</sub>
305	5	1.3	●	●	●	1.75	1.60	14.0 <sub>2)</sub>
306	6	1.3	●	●	●	1.35	1.45	12.0
307	7	1.3	●	●	●	1.75	1.60	11.0
308	8	0.9	●	●	●	1.50	1.25	10.0 <sub>1)</sub>
310	10	0.9	●	●	●	1.45	1.30	8.0 <sub>1)</sub>
312	12	0.7	●	●	●	1.25	1.35	7.0 <sub>1)</sub>
314	14	0.7	●	●	●	1.15	1.35	6.5 <sub>1)</sub>
316	16	0.7	●	●	●	0.95	1.25	6.0
318	18	0.7	●	●	●	0.85	1.20	5.5
319	19	0.7	●	●	●	0.95	1.25	5.0
326	26	0.5	●	●	○	0.95	1.30	2.0

**Note** : 1) rated current = 6A for socket with elbow (90°) contact for printed circuit.  
 2) rated current = 12A for socket with elbow (90°) contact for printed circuit.



Solder male contacts

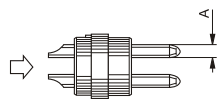

Solder female contacts

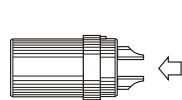

3B

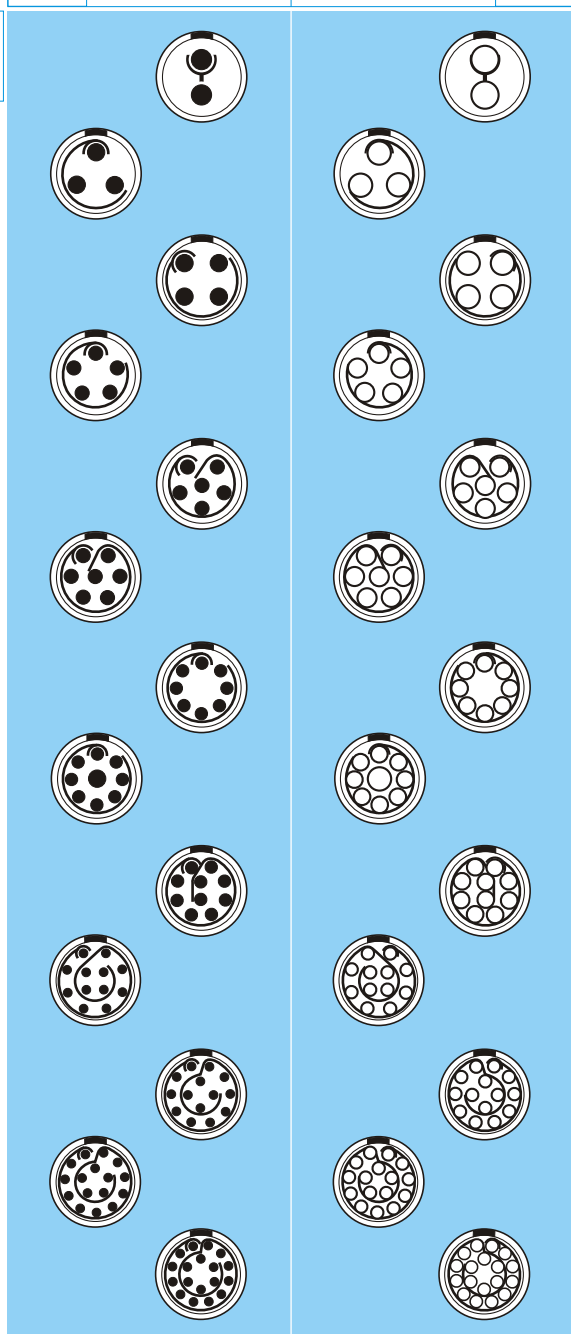

- First choice alternative
- Special order alternative

Reference	Multipole(contacts)	Φ A (mm)	Contact Type			Solder contact		Rated current (A)
			Solder	Print (straight)	Print (elbow)	Test voltage (kV rms) Contact-contact	Test voltage (kV rms) Contact-shell	
302	2	3.0	●	○	-	2.10	1.55	35.0
303	3	2.0	●	●	○	1.90	1.50	25.0
304	4	2.0	●	●	○	1.45	1.25	19.0
305	5	1.6	●	●	○	1.90	1.25	19.0
306	6	1.6	●	●	○	1.60	1.15	17.0
307	7	1.6	●	●	○	1.70	1.25	15.0
308	8	1.3	●	●	●	1.65	1.15	13.0
309	9	1.3	●	●	-	1.35	1.05	6.0
310	10	2.0	●	●	○	1.35	1.05	15.0
312	12	1.3	●	●	●	1.25	0.90	12.0
314	14	0.9	●	●	●	1.45	1.00	9.0
316	16	0.9	●	●	●	1.20	1.20	9.0 <sub>1</sub>
318	18	0.9	●	●	●	1.20	0.85	8.0

**Note :** 1) rated current = 6A for socket with elbow (90°) contact for printed circuit.  
 2) rated current = 12A for socket with elbow (90°) contact for printed circuit.  
 3) available only for connectors fitted with male contacts.



Ref.	Outer shell and collet nut		Latch sleeve + earthing crown		Other metallic components		Note
	Material	Surf. treatment	Material	Surf. treatment	Material	Surf. treatment	
C	Brass	chrome	brass/bronze	nickel	Brass	nickel	
N	Brass	chrome	brass/bronze	nickel	Brass	nickel	
H	Brass	black chrome	brass/bronze	nickel	Brass	nickel	
S	Stainless steel 304	anodized	brass/bronze	-	Brass	nickel	
L	Stainless steel 316L	anodized	Stainless steel 316L	-	Stainless steel 316L	-	
T	Brass	satin nickel	brass/bronze	nickel	Brass	nickel	
G	Brass	brown and black	brass/bronze	nickel	Brass	nickel	
F	Brass	High phosphorus chemical nickel	brass/bronze	nickel	Brass	nickel	
Z	Aluminium alloy	High phosphorus chemical nickel	brass/bronze	nickel	Brass	nickel	
Y	Brass	golden yellow	brass/bronze	nickel	Brass	nickel	

### Note:

#### Brass

Connectors are mostly brass case, which can meet most military or civil application requirements. The white surface of brass shell has nickel-chromium protective layer, which has remarkable effect in resisting industrial waste, salt spray and most corrosives.

In addition, we also have nickel plating, nickel-gold plating, nickel-black chromium plating and other options for application in specific environments of the anti-corrosion coatings.

#### Aluminium alloy

In the aviation, aerospace industry, portable mobile devices and so on. It is suitable for the connector with aluminium alloy shell.

In addition to its high mechanical lightness and excellent corrosion resistance, the surface of aluminium alloys can be protected by anodic plating, with a variety of colors to choose from.

#### Stainless steel

For the use of harsh environment, the surface coating is easy to be damaged. We recommend the use of stainless steel materials. AISI304 stainless steel and AISI316L stainless steel are usually used.

AISI304 stainless steel is recommended for special fields such as nuclear industry. It can resist radiation and nitric acid corrosion.

AISI316L stainless steel is recommended for medical and shipping industries. It has no surface treatment and strong corrosion resistance.

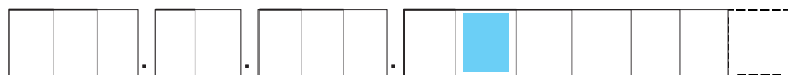

Ref.	Material	Contact type	Note
T	Teflon	Solder or print	
L	PPS	Solder or print	

## Contacts (B series)

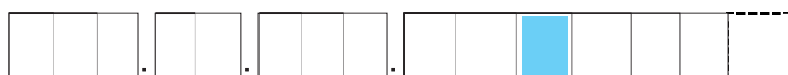

### Soldering characteristics

- no need to order specific tools, a simple soldering iron is sufficient
- ideal for very small and fragile conductors
- contacts with solder cups to allow the solder to flow

**Note:** see page 109 for more information.

### Contacts reference for plugs, free or fixed sockets

Contact type	Reference		Contact			Conductor					
	Male	Female	Φ A (mm)	Φ C (mm)	Form per fig.	Solid		Stranded			
						AWG min.	Section max. (mm <sup>2</sup> )	AWG		Section (mm <sup>2</sup> )	
								min.	max.	min.	max.
<b>Solder</b> 	A	L	0.5	0.40	-	28	0.09	-	30	-	0.05
			0.5	0.45	-	28	0.09	-	28	-	0.09
			0.7	0.60	-	24	0.25	-	26	-	0.14
			0.7	0.80	-	22	0.34	-	22	-	0.34
			0.9	0.80	-	22	0.34	-	22	-	0.34
			1.3	1.00	-	20	0.50	-	20	-	0.50
			1.6	1.40	-	16	1.00	-	18	-	1.00
			2.0	1.80	-	14	1.50	-	16	-	1.50
			3.0	2.70	-	10	4.00	-	12	-	4.00
			4.0	3.70	-	10	6.00	-	10	-	6.00
<b>Print</b> 	D	N	L dimensions and C are detailed in the section on PCB drilling pattern. See page 37.								
<b>Print (elbow)</b> 	V	V	L dimensions and C are detailed in the section on PCB drilling pattern. See page 37.								





### D and M type collets for B series

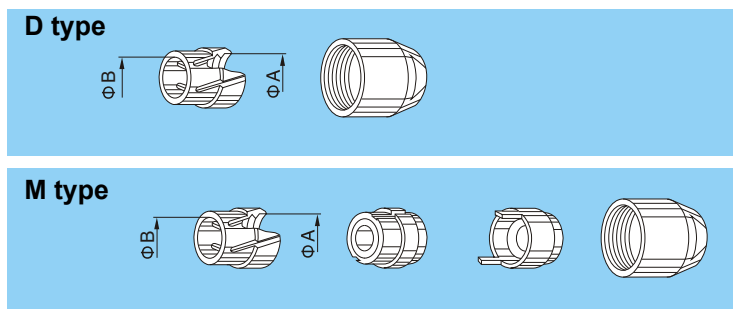

Reference		Collet ø		Cable ø		
Type	Code	ΦA	ΦB	max.	min.	
00	D 27	2.7	-	2.6	2.1	
	0B	D 32	3.2	-	3.0	2.1
		D 42	4.2	-	4.0	3.1
1B	D 52	5.2	4.7	5.0	4.1	
	M 31	3.1	-	3.0	2.6	
	D 42	4.2	-	4.0	3.1	
	D 52	5.2	-	5.0	4.1	
	D 62	6.2	-	6.0	5.1	
2B	D 72	7.2	6.7	7.0	6.1	
	M 42	4.2	-	4.0	3.1	
	D 52	5.2	-	5.0	4.1	
	D 62	6.2	-	6.0	5.1	
	D 72	7.2	-	7.0	6.1	
	D 82	8.2	-	8.0	7.1	
	D 92	9.2	8.6	9.0	8.1	
D 99	9.9	8.6	9.7	9.1		



## Bend relief for B series models with collet

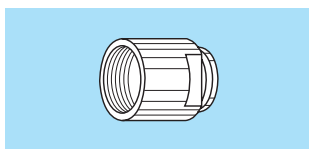

Need to be ordered

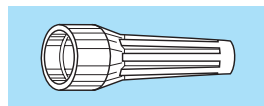

	Ref.	Collet		Need to be ordered separately (see page 108)
		Type	Code	
<b>00</b>	z	D	17 to 35	GMA.00.... GMB.00....
<b>0B</b>	z	D	21 to 52	GMA.0B....
<b>1B</b>	z	M	27 and 31	GMA.1B....
		D	42 to 72	GMA.1B....
<b>2B</b>	z	M	21 and 31	GMA.0B....
		D	42	GMA.2B....
		D	52 to 92	GMA.2B....
<b>3B</b>	z	M	52	GMA.1B....
		D	62 to 11	GMA.3B....
<b>4B</b>	z	M	62 and 72	GMA.2B....
		M	82 and 92	GMA.4B....
		D	10 to 15	GMA.4B....

### Plug assembly instructions for B series

---

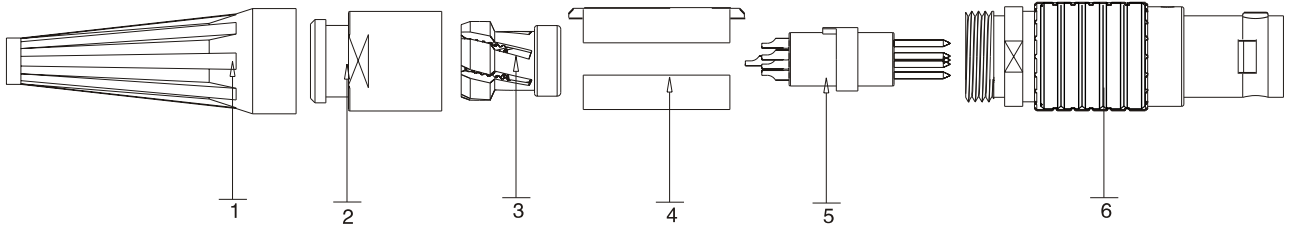

1. Pass the cable through the bend relief ①, the collet nut ②, the cable collet ③, and solder to the insulator with contacts ⑤ in order.
2. Attach two pieces of split insert carriers ④ to the welded insulator with contacts ⑤, noting that the window on the split insert carriers ④ corresponds to the protrusion on the insulator with contacts ⑤.
3. Install the cable collet ③ in the proper position of the cable. Note that the protrusion on the cable collet ③ corresponds to the groove on the split insert carriers ④.
4. Push the insulator with contacts ⑤, the split insert carriers ④ and the cable collet ③ into the plug assembly in turn, and note that the protrusions on the split insert carriers ④ are correspondingly inserted into the notches in the plug assembly.
5. Screw the collet nut ② onto the housing subassy ⑥
6. Insert the bend relief ① into the corresponding step of the collet nut ②.

### B Series

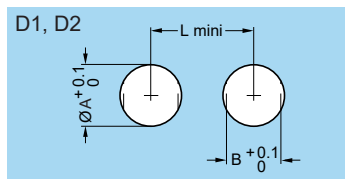

series	D1			D2		
	ØA	B	L	ØA	B	L
00	7.1	6.4	12.5	7.1	-	12
0B	9.1	8.3	14.5	9.1	8.3	15
1B	12.1	10.6	18.5	12.1	10.6	19
2B	15.1	13.6	22.5	15.1	13.6	23
3B	18.2	16.6	27.0	18.2	16.6	27

**Note:** when using the tapered washer a round hole apply 00:  $\varnothing$  7.6 mm / 0B:  $\varnothing$  9.6 mm / 1B:  $\varnothing$  12.6 mm / 2B:  $\varnothing$  15.7 mm / 3B:  $\varnothing$  18.8 mm

### Cut-out types

Model	Type
ZCG	D1
ZEG	D1
ZGG	D1
ZHG	D1
TAG	D1
DFG	D1

Model	Type
MEG	D2
MGG	D2
MHG	D2
TWG	D2

### Mounting nut torque

series	Torque (Nm)
	Metal shell
00	1.0
0B	2.5
1B	4.5
2B	6.0
3B	9.0

**Note:** these values apply when metal shell are mounted with insulating washer.

### Panel cut-out for mounting with insulating washer

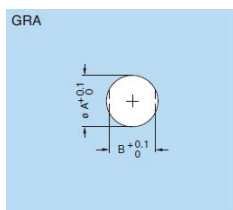

series	D i m .(mm)	
	ØA	B
00	8.9	8.1
0B	10.9	10.1
1B	13.9	12.3
2B	18.0	16.3

### Type-0 PCB drilling pattern

	PCB(Straight Contact)	PCB(Elbow Contact)	PCB(ZPG/ZXG Elbow Socket)	
Contacts				
2	Drill: 0,8 mm 	Drill: 0,7 mm 	Drill-contact: 0,8 mm Drill-mounting: 0,8 mm 	
3	Drill: 0,8 mm 	Drill: 0,7 mm 	Drill-contact: 0,8 mm Drill-mounting: 0,8 mm 	
4	Drill: 0,6 mm 	Drill: 0,7 mm 	Drill-contact: 0,8 mm Drill-mounting: 0,8 mm 	
5	Drill: 0,6 mm 	Drill: 0,7 mm 	Drill-contact: 0,8 mm Drill-mounting: 0,8 mm 	
6	Drill: 0,6 mm 	Drill: 0,7 mm 	Drill-contact: 0,8 mm Drill-mounting: 0,8 mm 	
7	Drill: 0,6 mm 	Drill: 0,7 mm 	Drill-contact: 0,8 mm Drill-mounting: 0,8 mm 	

### Type-1 PCB drilling pattern

	PCB(Straight Contact)	PCB(Elbow Contact)	PCB(ZPG/ZXG Elbow Socket)	
Contact				
2	Drill: 0,8 mm 	Drill: 0,9 mm 	Drill-contact: 0,8 mm Drill-mounting: 0,8 mm 	
3	Drill: 0,8 mm 	Drill: 0,9 mm 	Drill-contact: 0,8 mm Drill-mounting: 0,8 mm 	
4	Drill: 0,6 mm 	Drill: 0,7 mm 	Drill-contact: 0,8 mm Drill-mounting: 0,8 mm 	
5	Drill: 0,8 mm 	Drill: 0,7 mm 	Drill-contact: 0,8 mm Drill-mounting: 0,8 mm 	
6	Drill: 0,6 mm 	Drill: 0,7 mm 	Drill-contact: 0,8 mm Drill-mounting: 0,8 mm 	

## Type-1 PCB drilling pattern

	PCB(Straight Contact)	PCB(Elbow Contact)	PCB(ZPG/ZXG Elbow Socket)
Contact			
7	Drill: 0,6 mm 	Drill: 0,7 mm 	Drill-contact: 0,8 mm Drill-mounting: 0,8 mm 
8	Drill: 0,6 mm 	Drill: 0,7 mm 	Drill-contact: 0,8 mm Drill-mounting: 0,8 mm 
10	Drill: 0,6 mm 	Drill: 0,7 mm 	Drill-contact: 0,8 mm Drill-mounting: 0,8 mm 
14	Drill: 0,6 mm 	Drill: 0,7 mm 	
16	Drill: 0,6 mm 	Drill: 0,7 mm 	

## Type-2 PCB drilling pattern

	PCB (Straight Contact)	PCB (Elbow Contact)		PCB (Straight Contact)	PCB (Elbow Contact)
Contact			Contact		
3	Drill: 0,8 mm Bohrung: 0,8mm 	Drill: 0,9 mm 	10	Drill: 0,8 mm 	Drill: 0,7 mm 
4	Drill: 0,8 mm 	Drill: 0,9 mm 	12	Drill: 0,6 mm 	Drill: 0,7 mm 
5	Drill: 0,8 mm 	Drill: 0,9 mm 	14	Drill: 0,6 mm 	Drill: 0,7 mm 
6	Drill: 0,8 mm 	Drill: 0,9 mm 	16	Drill: 0,6 mm 	Drill: 0,7 mm 
7	Drill: 0,8 mm 	Drill: 0,7 mm 	18	Drill: 0,6 mm 	Drill: 0,7 mm 
8	Drill: 0,8 mm 	Drill: 0,9 mm 	19	Drill: 0,6 mm 	Drill: 0,7 mm 



## Length of straight print contacts

For Socket Z●●

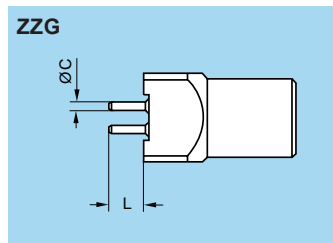
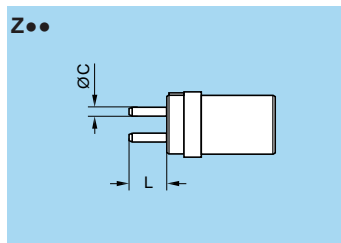

	Type	Size	
		ØC	L
00	302	0.5	3.0
	303	0.5	3.0
	304	0.5	3.0
0B 0K	302/303	0.7	3.2
	304/305	0.5	3.2
	306/307/309	0.5	3.2
1B 1K	302/303/304/305	0.7	3.0
	306/307/308	0.7	3.0
	310/314/316	0.5	4.0
2B 2K	303/304/305/306/307	0.7	3.0
	308/310/312/314/316/318/319	0.7	3.0
	326	0.7	3.0

	Type	ZZG	
		ØC	L
0B	302/303	0.7	4.5
	304/305	0.5	4.5
	306/307/309	0.5	3.0
1B	302/303/304/305	0.7	3.8
	306/307/308	0.7	3.8
	310/314/316	0.5	3.8
2B	303/304/305	0.7	5.5
	306/307/308/310	0.7	5.5
	312/314/316/318/319	0.7	5.5

**Note:** This table does not apply for socket M●●; socket ZH● and plugs TA●/TW●.

### Fixed socket for printed circuit (ZZG)

Holes for fixing the housing

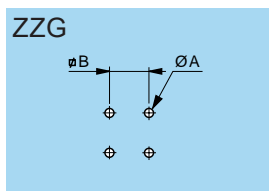

Serie	Size	
	A	B
00	0.8 <sup>1)</sup>	5.08
0B	1.7 <sup>2)</sup>	7.62
1B	1.7 <sup>2)</sup>	7.62
2B	1.7 <sup>2)</sup>	10.16

**Note:** Mounting torque for screws: 0.1 Nm. 1) to solder. 2) to screw.