

## UL29 series

### Technical specification:

Working temperature	-55 ° C ~ +125 ° C
Relative humidity	90%~95% (40±2°C)
Working pressure	4.39KPa~101.33KPa
Salt spray	72 hours in 5% NaCl mist
Vibration	10Hz~200GHz,
Impact	980 m / s <sup>2</sup> , instantaneous break <1μs
Mechanical life	3000 times
Insulation resistance	≥5000MΩ (normal)
Working current	8A
Contact resistance	< 10MΩ
Withstand voltage ( sea level )	1150V (AC)

### Construction:

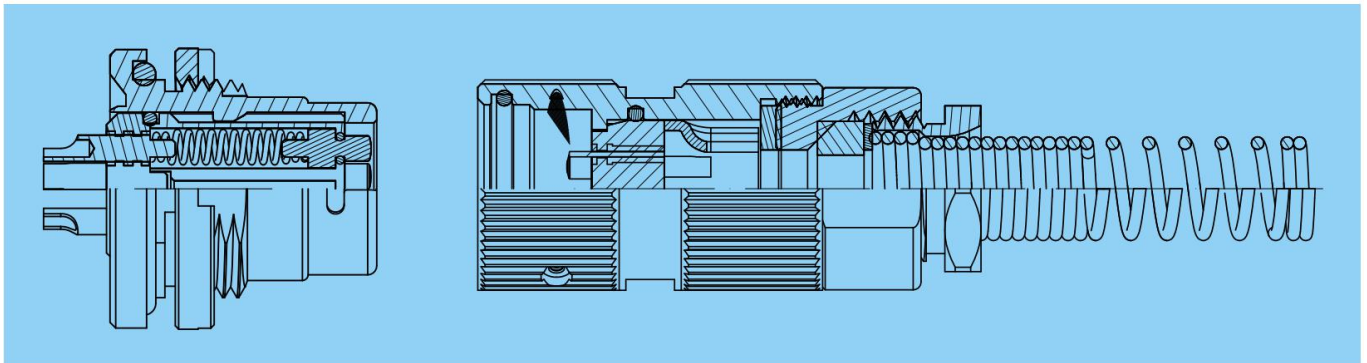

**UL29 series product numbering rules:**

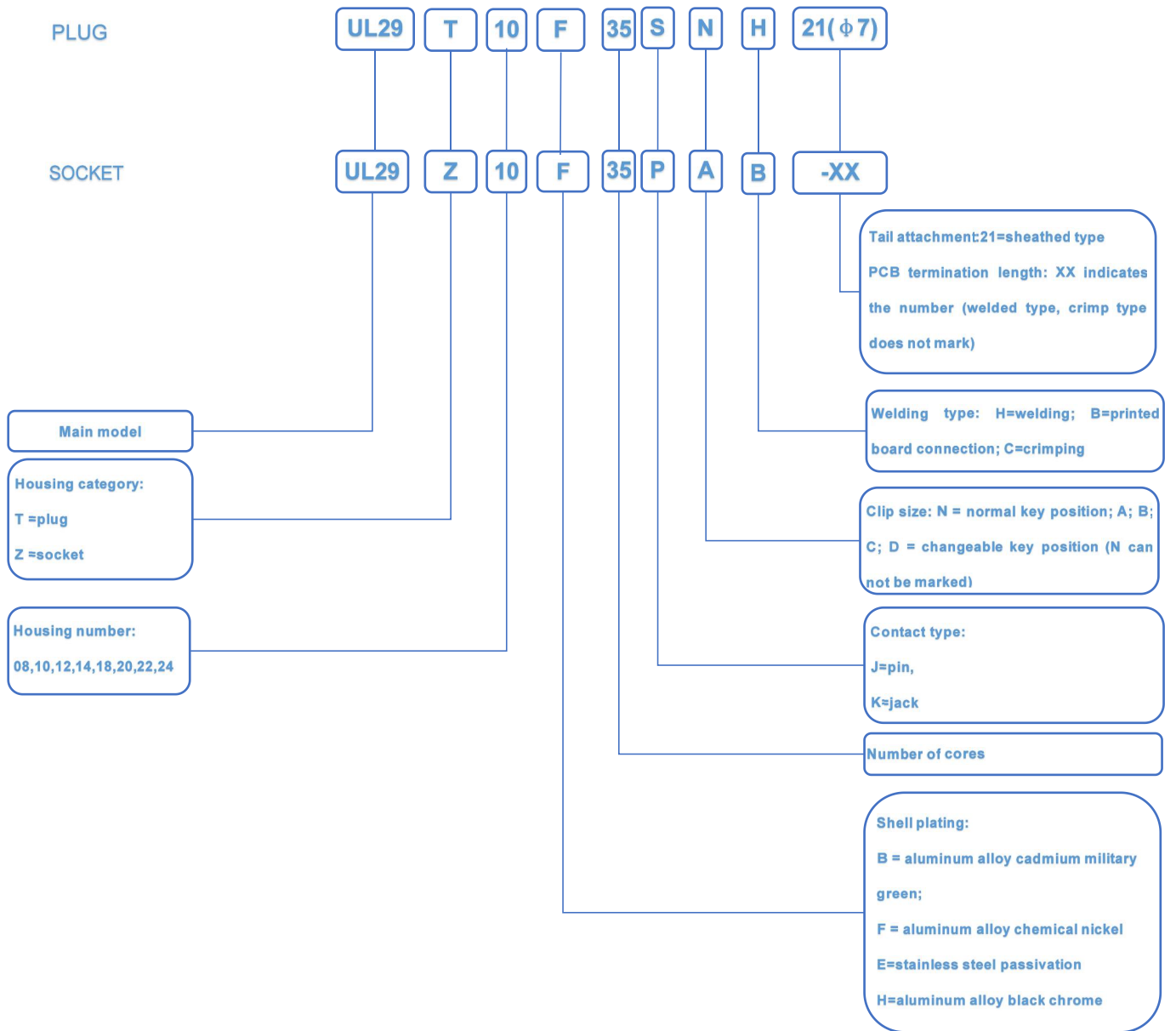

UL29 plug detail

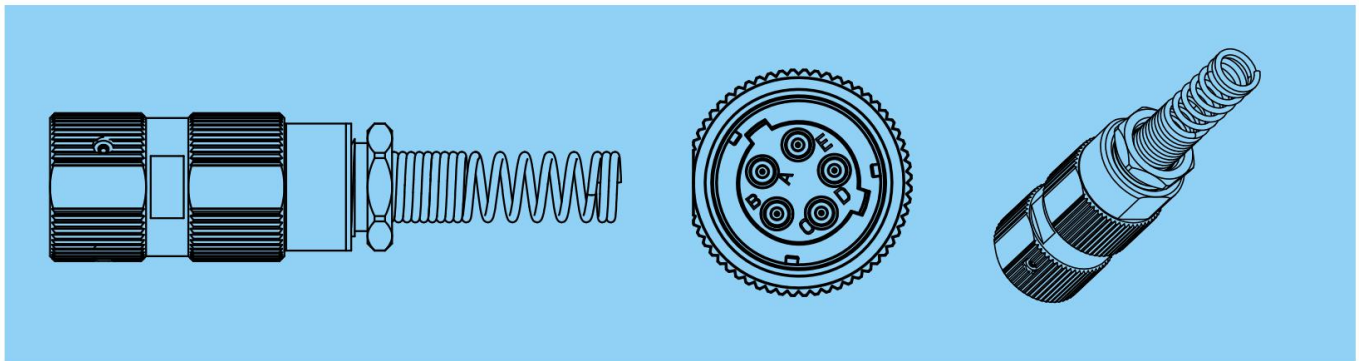
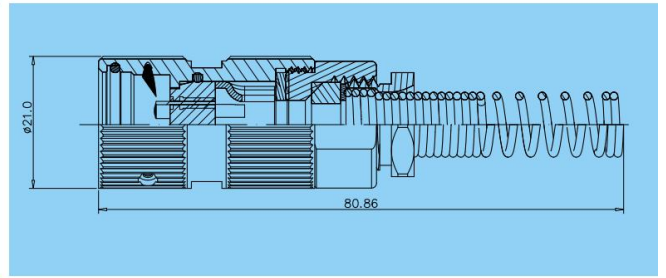
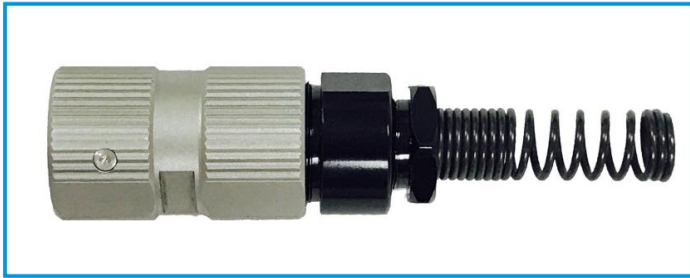

UL29 socket detail

